

AERODROME OBSTACLE
CHART - ICAO

TYPE **A** (OPERATING LIMITATIONS)

DIMENSIONS IN METRES, ELEVATIONS IN FEET AND METRES

MURMANSK, RUSSIA
MURMANSK
RWY 31

MAGNETIC VARIATION 16°E

| DECLARED DISTANCES | |
|------------------------------------|----------------|
| TAKE-OFF RUN AVAILABLE | RWY 31 2500 |
| TAKE-OFF DISTANCE AVAILABLE | 2900 |
| ACCELERATE-STOP DISTANCE AVAILABLE | 2500 |
| LANDING DISTANCE AVAILABLE | 2500 |

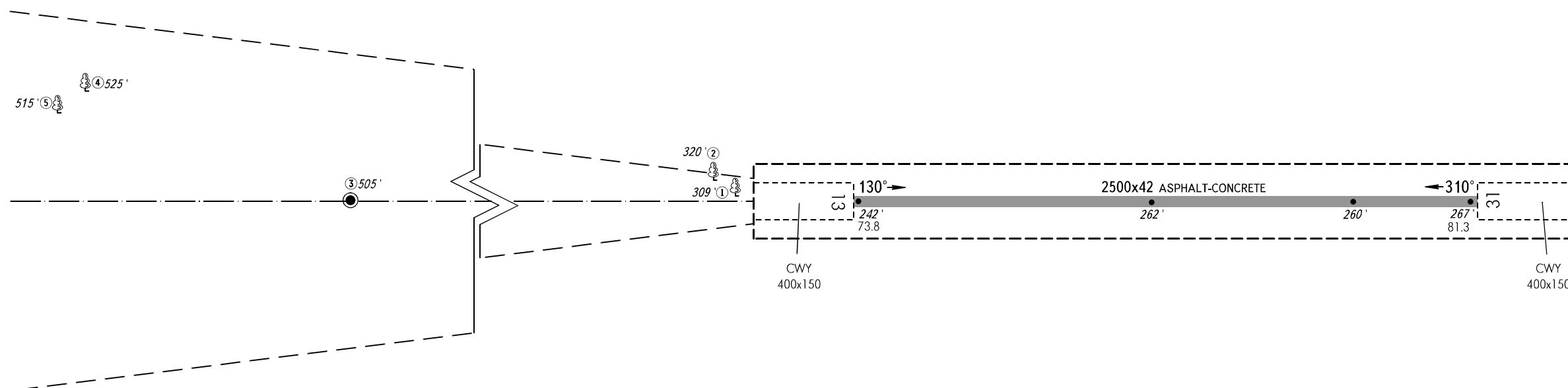
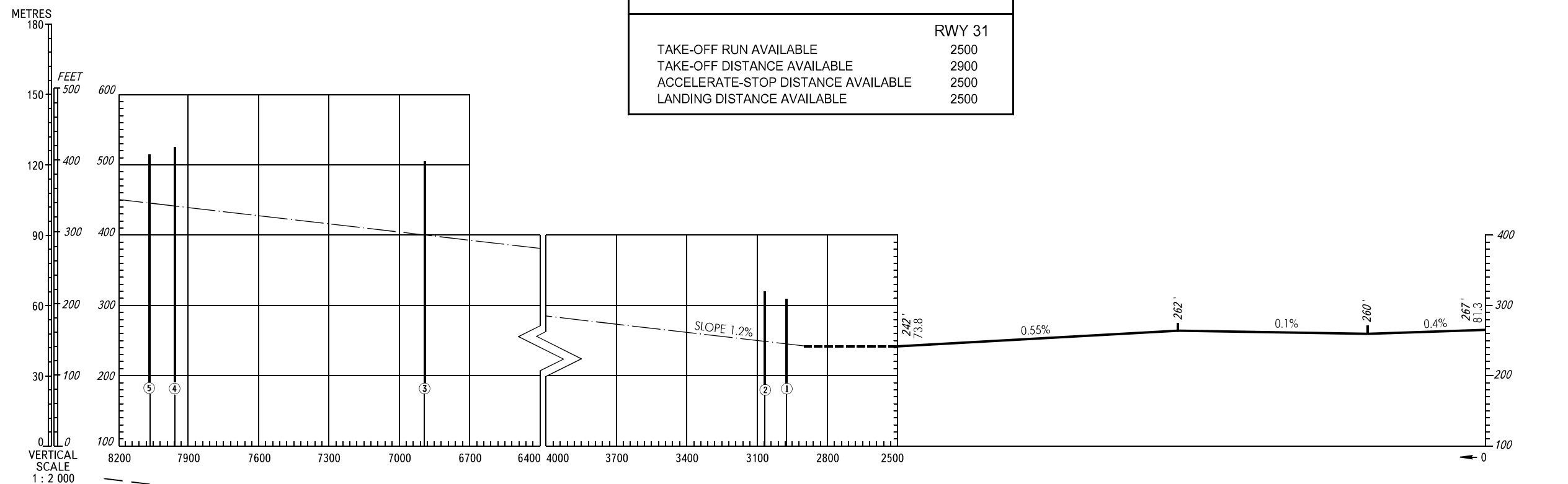

LEGEND

| | |
|----------------------------------|---|
| IDENTIFICATION NUMBER | ① |
| POLE, TOWER, SPIRE, ANTENNA, ETC | ● |
| TREE | 🌳 |
| | |
| | |

